

High Capacity

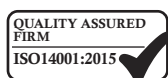

RAPID1000

The large scale, RAPID1000 incinerator is the latest innovative design from Addfield joining our High Capacity incineration range.

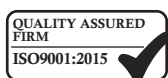

The Rapid1000 high capacity incinerator is an ideal solution to batch loading of solid waste. Having a 3000kg loading capacity and reinforced loading chamber enables even large waste to be easily loaded. Designed for easy and fast deployment for static installation alongside mobile options. Providing essential support to maintaining biosecurity.

Built to rapidly handle a wide range of solid waste able to achieve a burn rate of 500kg/hr to 1000kg/hr. A highly robust and thermally efficient solution benefiting from an advanced burn chamber to ensure a smooth and equal burn. Multiple sub chamber doors allow rapid de-ashing during and after the incineration process has been completed.

Machine Specification

External L x W x H (mm)	8206 x 2325 x 2273/6470
Internal Upper Chamber L x W x H (mm)	3710 x 1510 x 1125(peak)
Internal Lower Chamber L x W x H (mm)	3710 x 1510 x 370
Load Chamber Volume (m ³)	5.1
Weight (approx tonnes)	26.2
Max Load Capacity (kg)	3000
Nominal Burn Rate (kg/hr)	500 to 1000
Thermal Capacity (kW)	2250
Power Supply 50/60 hz	318/415v
Door Aperture	3650 x 1450
Control Panel	PLC
Fuel Types	Diesel, LPG, N-Gas
Insulation Board	25mm
Insulation Fire Brick	Grade E23
Fire Brick (Alumina)	42.5%

*We reserve the right to change the specification, dimensions and quality of materials from time to time, so long as the alteration is minor or an improvement to the said product.

Primary Chamber

- Fully insulated internal refractory lining, constructed from high grade refractory brick ensuring a self-supporting, interlocked arrangement.
- Fully interlocked, manually operated, access door.
- Waste ignition burner, temperature controlled on-off, complete with internal air fans.
- Grated hearth combustion burner, temperature controlled on-off, complete with internal air fans.
- Secondary combustion burner air fans with automatically controlled distribution to their designated area.
- One temperature sensor mounting points.

Secondary Chamber

- Fully insulated internal refractory lining. Constructed from high grade low thermal mass insulation.
- Temperature controlled Secondary chamber burnout burner with automatic on-off control, complete with internal air fans.
- Integrated combustion burner air fans automatically controlling distribution to designated areas.
- Temperature sensor mounting point at the top of the chamber, ensuring the chamber reaches the required 850°C minimum, with a 2 second retention time.

Waste Type

Agricultural Waste	✓
Medical Waste	✓
General (municipal) Waste	✓

High Capacity

RAPID1000



Waste Loading and De-Ashing

Loading can be carried out either mechanically or manually through the vertical opening hydraulically operated lid. The ash removal will be manually through the front ash doors, a full set of de-ashing tools are included with every Rapid machine. To de-ash simply push the de-ashing button on the control panel, this will isolate the lower burners to allow ash doors to open for ash removal.

The Addfield Difference

- Pre-fabricated 8mm & 10mm robust mild steel casing, seam welded and suitably stiffened/ braced where necessary.
- Lightweight resilient refractory fibre insulation door, providing a tight seal, giving excellent thermal efficiency.
- Primary lining thickness 190mm, rated at 1450°C.
- Low thermal mass roof lining, with removable roof and back plate for ease of maintenance.
- Paint finishing – The steel structures are completely painted using a two-pack high grade paint system.
- Unique Grated Hearth technology designed for the increased efficiency of material incineration.
- A 190mm thick refractory lining, using andalusite and insulation bricks, improving thermal efficiency.



Additional Operation Equipment



Control Panel

Specially designed control panels, to manage your incineration. Pre-programmed and able to be manually adjusted for optimal results. Push button and touch screen control with optional data logging system.



Fuel Tank

Allowing you to operate the incinerator in all locations as well as providing a backup to your traditional supply. Available in 1000 to 5000 litre capacity. Fuel can be safely stored and monitored in close proximity to your incinerator.



Venturi System

An advanced flue gas treatment system designed to further reduce dust, acid gasses, dioxins and furans. Highly effective the venturi is widely regarded as the leading treatment system in its field.

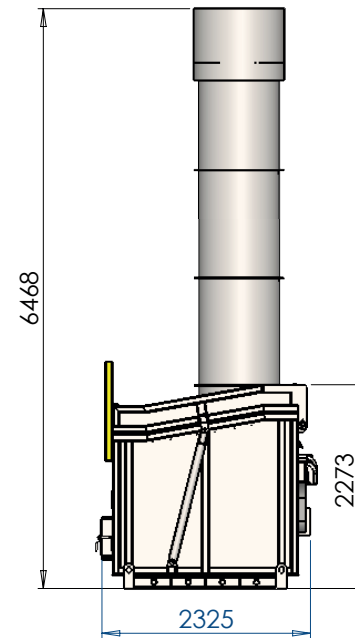
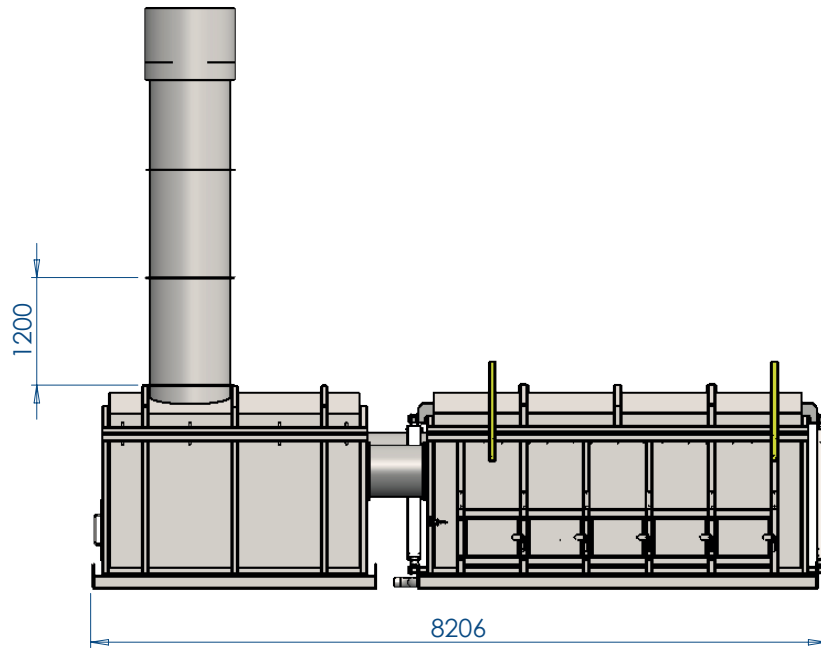
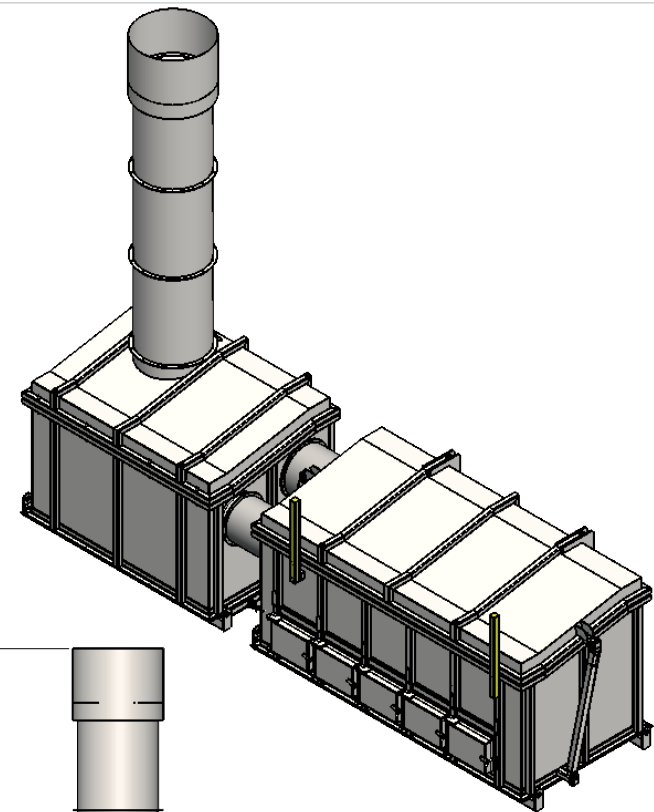
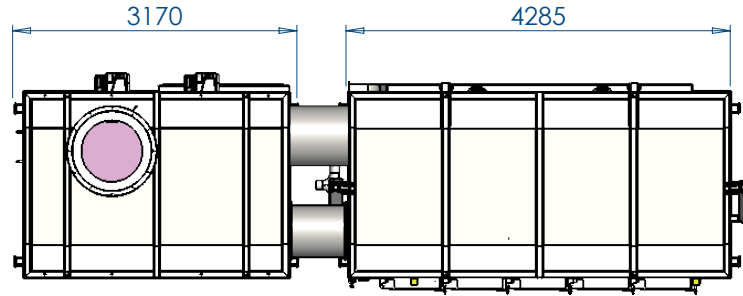

Material:
Plain Carbon Steel
Specification:
n/a
Finish:
NONE
Scale: 1:60

Drawn by:
Harjot Bhullar
Approved by:
Last saved date
06/03/2018

Notes:
ALL DIMENSIONS ARE SUBJECT TO CHANGE AND SHOULD BE USED AS A GUIDE ONLY
Dimensions in Millimeters

addfield
Incinerate • Cremate

THIS DRAWING AND ALL INFORMATION CONTAINED HEREON IS THE PROPERTY OF ADDFIELD ENVIRONMENTAL SYSTEMS LIMITED, WITHOUT WHOSE PERMISSION IT MAY NOT BE COPIED SHOWN OR OTHERWISE USED AND IT IS TO BE RETURNED PROMPTLY ON REQUEST.

10 April 2017 14:32:49

Tolerances, Unless otherwise stated
WHOLE NUMBERS ± 0.20
1 DECIMAL PLACE ± 0.10
2 DECIMAL PLACE ± 0.05
ANGLES ± 0.5°
Maximum Surface Finish, Unless otherwise stated 3.2

Title:
RAPID GA
Drawing Number:
Rapid GA -B

Design Approval
REV. 1
B 1