

Medical



**MP-300** Secure and reliable medical pathological (MP) waste incineration.  
 The MP range is specially designed for safely incinerating hazardous high moisture biological red bag waste.



The MP-300 is a mid-sized medical incinerator. Securely destroying a complete range of Medical, Pathological and Clinical waste. Designed and built along the latest advances in medical incineration.

Benefiting from Hot Hearth technology, efficiently recycling heat throughout and below the primary chamber, delivering complete 360° heating.

Unrivalled in it's field boasting a 40% reduction in fuel consumption compared to alternative solutions. The MP-300 is ideally suited for facilities of between 400-600 beds and equivalent.

Machine Specification	
External L x W x H (mm)	3156 x 1150 x 1945/3600
Internal L x W x H (mm)	1600 x 675 x 700
Chamber Volume (m³)	0.76
Weight (approx tonnes)	3.6
Max Load Capacity (kg)	300
Nominal Burn Rate (kg/hr)	<50
Power Supply 50/60 hz (single phase)	220 - 240v <small>(single phase 110-120v on request)</small>
Thermal Capacity** (kW)	390
Door Aperture	675 x 550
Hot Hearth Principle	Double Pass
Fuel Types	Diesel, LPG, N-Gas
Control Panel	AIC
Insulation Board	25mm
Insulation Fire Brick	Grade E23
Fire Brick (Alumina)	42.5%

\*We reserve the right to change the specification, dimensions and quality of materials from time to time, so long as the alteration is minor or an improvement to the said product.

\*\*Actual not maximum. Please consult Addfield directly for gas set-up requirement.

- ### Primary Chamber
- Heavily insulated internal refractory lining. Constructed from high grade refractory brick ensuring a secure self supporting, interlocking arrangement.
  - Manually opening, securely locking, access door with viewing port.
  - Automatic temperature controlled on-off waste ignition burner complete with internal air fans.
  - Hot Hearth Combustion Burner, temperature controlled on-off, complete with internal air fans.
  - Secondary combustion burner air fans, automatically controlled distribution to their designated area.
  - Two temperature sensor mounting points.
- ### Secondary Chamber
- Fully insulated internal refractory lining. Constructed from high grade refractory brick and low thermal mass insulation.
  - Secondary chamber burnout burner, temperature controlled on-off complete with internal air fans
  - Automatically controlled integrated combustion burner air fans.
  - Temperature sensor mounting point at the base of the exit flue ensuring the chamber reaches the necessary 1100°C minimum, with a 2 second retention time.

Waste Type		
	Clinical Waste	✓
	Treated Waste	✓
	Anatomical Waste	✓
	Cytotoxic & Cytostatic Waste	✓
	Offensive/Hygiene Waste	✓
	Medicinal Waste	✓
	Domestic (municipal) Waste	✓

Medical

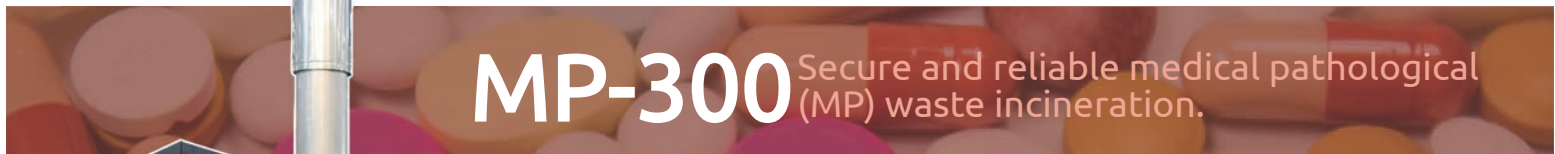

# MP-300

Secure and reliable medical pathological (MP) waste incineration.



## Waste Loading and De-Ashing

The MP series of incinerators are ergonomically designed for easy and safe loading of all medical waste streams. Loading through the front facing door can be completed manually or with the aid of a hydraulic lifting table. The MP machines can be loaded multiple times throughout a cycle. At the end of every incineration process, ash should be discharged through the loading door onto the supplied catcher tray prior to being loaded for the next burn.

## The Addfield Difference

- Pre-Fabricated 8mm & 10mm robust mild steel casing, seam welded and suitably stiffened/ braced where necessary.
- Lightweight resilient refractory fibre insulation door, providing a tight seal, giving excellent thermal efficiency.
- Primary and secondary chamber lining thickness 180mm rated up-to 1650°C.
- Premium paint finish - Steel structures are painted using a two-pack high grade paint system.
- Unique Hot Hearth technology enabling increased efficiency of incineration by providing additional heating below the chamber encouraging 360° heat distribution.
- Multi-layered refractory lining using fire bricks and insulation bricks, improving thermal efficiency.



## Additional Operation Equipment



### Bin Tipper

The safest way to load hazardous waste directly into top loading ram loaders. Hands free operation for up to 150kg, compatible with the majority of waste bins. Reliable hydraulically operated mechanism.



### Ram Loader

Built to enable the option of continuous loading throughout operation. Securely positioning waste into the primary chamber whilst maintaining temperature and preventing radiant heat and thermal shock.



### Venturi System

An advanced flue gas treatment system designed to further reduce dust, acid gasses, dioxins and furans. Highly effective the venturi is widely regarded as the leading treatment system in its field.

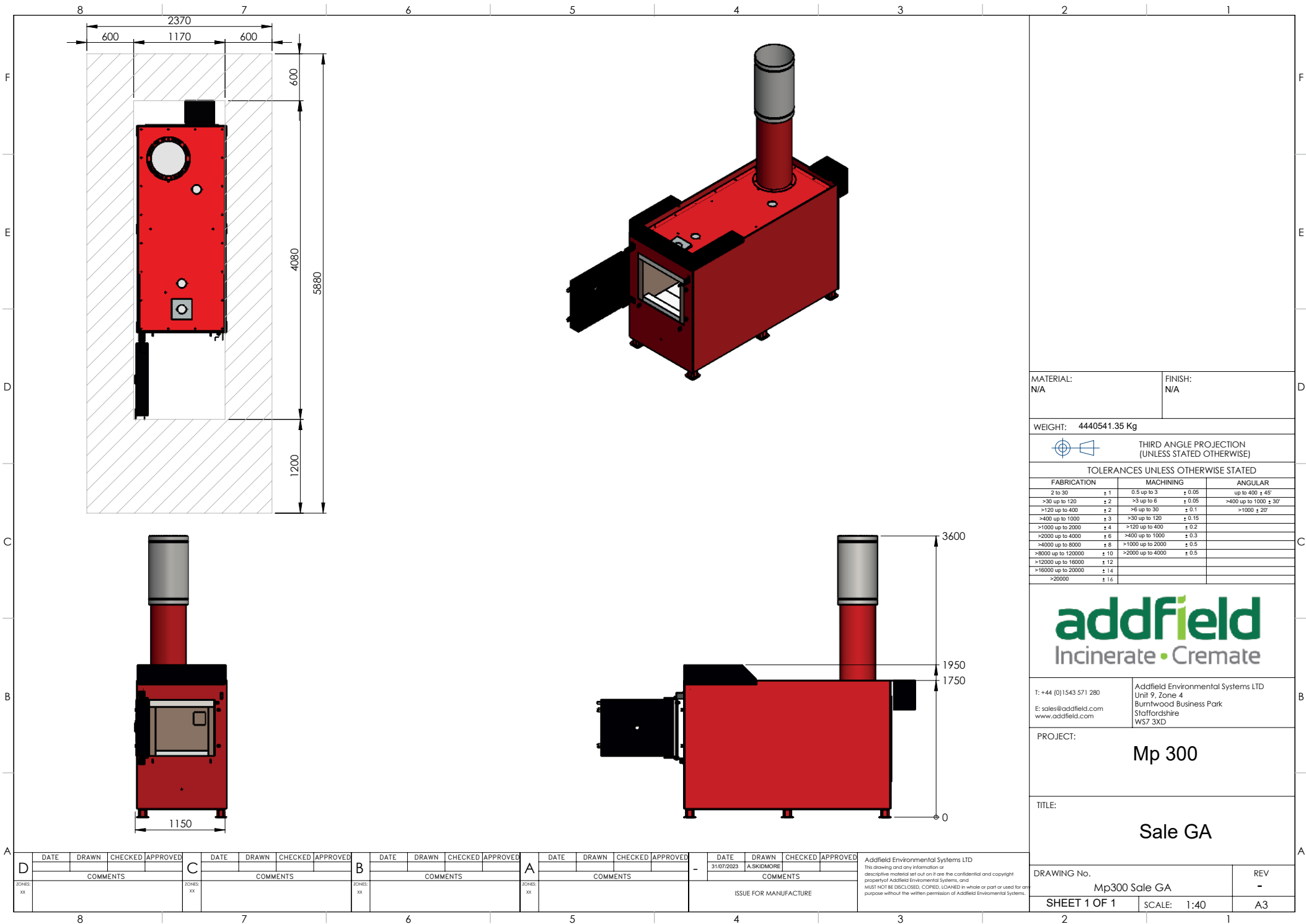

MATERIAL: N/A  
FINISH: N/A

WEIGHT: 4440541.35 Kg

THIRD ANGLE PROJECTION (UNLESS STATED OTHERWISE)

TOLERANCES UNLESS OTHERWISE STATED

FABRICATION	MACHINING	ANGULAR
2 to 30 ± 1	0.5 up to 3 ± 0.05	up to 40° ± 45'
>30 up to 120 ± 2	>3 up to 6 ± 0.05	>400 up to 1000 ± 30'
>120 up to 400 ± 2	>6 up to 30 ± 0.1	>1000 ± 20'
>400 up to 1000 ± 3	>30 up to 120 ± 0.15	
>1000 up to 2000 ± 4	>120 up to 400 ± 0.2	
>2000 up to 4000 ± 6	>400 up to 1000 ± 0.3	
>4000 up to 8000 ± 8	>1000 up to 2000 ± 0.5	
>8000 up to 120000 ± 10	>2000 up to 4000 ± 0.5	
>12000 up to 16000 ± 12		
>16000 up to 20000 ± 14		
>20000 ± 16		



T: +44 (0)1543 571 280  
E: sales@addfield.com  
www.addfield.com

Addfield Environmental Systems LTD  
Unit 9, Zone 4  
Burntwood Business Park  
Staffordshire  
WS7 3XD

PROJECT: Mp 300

TITLE: Sale GA

DRAWING No. Mp300 Sale GA  
SHEET 1 OF 1 SCALE: 1:40 REV - A3

DATE	DRAWN	CHECKED	APPROVED	DATE	DRAWN	CHECKED	APPROVED	DATE	DRAWN	CHECKED	APPROVED	DATE	DRAWN	CHECKED	APPROVED	DATE	DRAWN	CHECKED	APPROVED	
COMMENTS				COMMENTS				COMMENTS				COMMENTS				COMMENTS				
ZONES: xx				ZONES: xx				ZONES: xx				ZONES: xx				ZONES: xx				
ISSUE FOR MANUFACTURE																Addfield Environmental Systems LTD This drawing and any information or descriptive material set out on it are the confidential and copyright property of Addfield Environmental Systems, and MUST NOT BE DISCLOSED, COPIED, LOANED in whole or part or used for any purpose without the written permission of Addfield Environmental Systems.				