

## Pet Cremation

# A50L Large Capacity Mass Pet Cremation Machine

An oversized pet cremation machine designed for high throughput communal cremation operation.

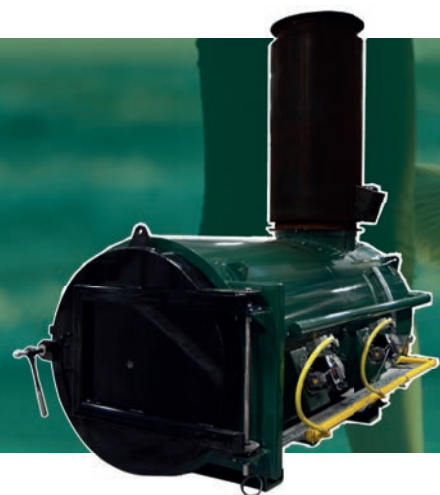

A highly optimised solution for securely managing mass pet cremations enabling the processing of several simultaneous pet cremations in a day.

Regularly installed in growing and established pet crematorium due to its compact and efficient operation. Also trusted by research centres, kennels, and animal rescue facilities.

Equipped with the necessary sophistication of control and designed to cremate pets and mixed animal carcasses in a safe, clean and environmentally friendly manner.

## Machine Specification

External L x W x H (mm)	3735 x 3175 x 3600/7330
Internal L x W x H (mm)	3035 x 1170 Ø
Chamber Volume (m <sup>3</sup> )	3.26
Weight (approx tonnes)	8.6
Nominal Burn Rate UK* (kg/hr)	<50
Burn Rate [Export Only]* (kg/hr)	100 - 150
Thermal Capacity (kW)	770
Power Supply 50/60 hz	220 - 250v
Door Aperture	1170 Ø
Fuel Types	Diesel, LPG, N-Gas
Control Panel	AIC
Insulation Fire Brick	Grade E23
Insulation Board	25mm
Fire Brick (Alumina)	42.5%

\*We reserve the right to change the specification, dimensions and quality of materials from time to time, so long as the alteration is minor or an improvement to the said product.

## Primary Chamber

- Heavily insulated internal refractory lining. Constructed from high grade refractory brick ensuring a secure self-supporting, interlocking arrangement.
- Manually opening, securely locking, access door with viewing port.
- Automatic temperature controlled on-off waste ignition burner complete with internal air fans.
- Temperature controlled, on-off combustion burners, complete with internal air fans.
- One temperature sensor mounting point.

## Secondary Chamber

- Fully insulated internal lining, constructed from a choice of high grade and robust fibre or concrete.
- Secondary chamber burnout burner, temperature controlled on-off, complete with internal air fans.
- Automatically controlled integrated combustion burner air fans.
- Temperature sensor mounting point at the base of the exit flue ensuring the chamber reaches the necessary 850°C minimum, with a 2 second retention time.
- Secondary combustion burner air fans, automatically controlled distribution to their designated area.

## Optional Extras

	De-ashing Tool	✓
	Pet & Horse Cremulator	✓
	Lift Table	✓
	Fuel Tank	✓
	Spares Kit & Servicing	✓

# A50L Large Capacity Mass Pet Cremation Machine.

## Waste Loading and De-Ashing

The A50L cremator has been designed to allow for easy and safe loading of multiple pets for each cremation cycle. A wide front opening door provides access to the primary chamber for loading to be completed manually or with the aid of a hydraulic lifting table. This system can be safely loaded multiple times throughout a cycle to ensure maximum output can be achieved. At the end of every cremation process ash should be removed prior to the next burn.



## The Addfield Difference

- Pre-Fabricated 8mm & 10mm robust mild steel casing, seam welded and suitably stiffened/ braced where necessary.
- Lightweight resilient refractory fibre insulation door, providing a tight seal, giving excellent thermal efficiency.
- Primary chamber lining thickness 150mm rated up-to 1450°C. Manufactured using our unique 3 layered brick based refractory, with a reinforced concrete finish around the door and along the floor.
- Premium paint finish - Steel structures are painted using a two-pack high grade paint system.
- Multi-layered refractory lining using fire bricks, insulation board and insulation bricks, improving thermal efficiency.
- Multi-lingual control panel options.

## Additional Operation Equipment



### Waste Hopper

The optional hopper is perfect for offering a safe and continuous loading of pets equipped with an automatic operated door for loading into the centre of the primary chamber.



### De-ashing Tools

De-ashing tools increase the comfort of de-ashing the cremator. Associated with removing hot ash from the chamber of the cremator straight into the ash box, ready to be processed in the cremulator unit.



### Equine Cremulator

The Equine Cremulator is equipped with a large cylindrical processing chamber to finely convert the final remains left after cremation into a fine easy to dispose of ash.

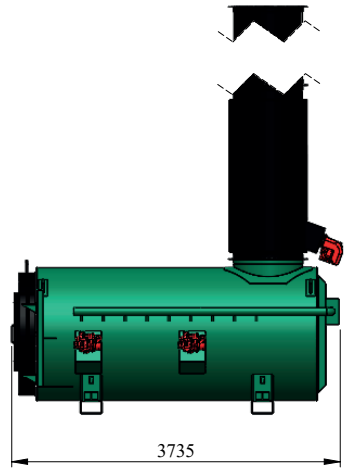
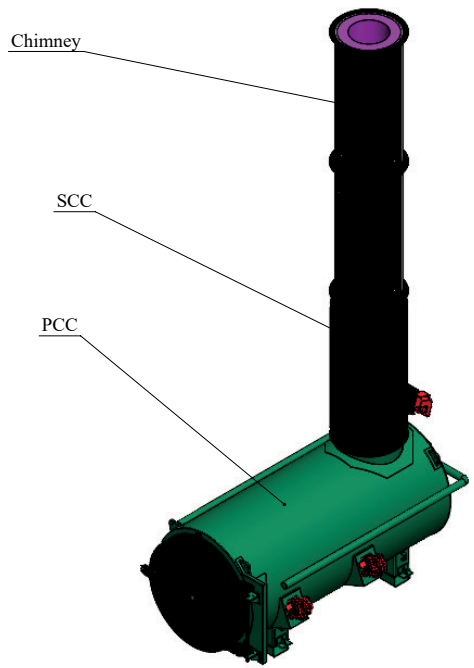
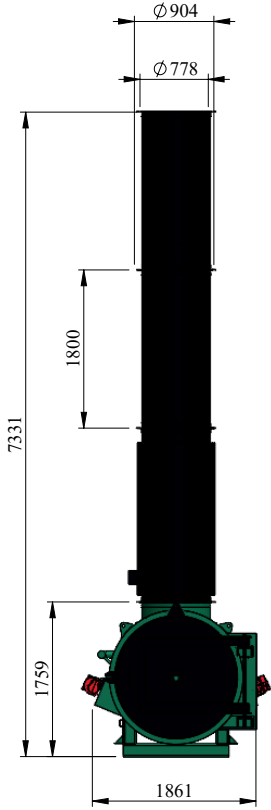
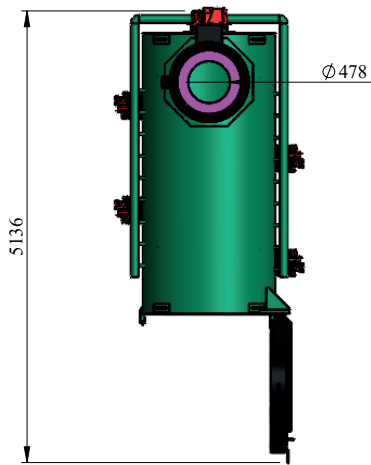

MATERIAL: N/A  
FINISH: N/A

WEIGHT: N/A



THIRD ANGLE PROJECTION  
(UNLESS STATED OTHERWISE)

TOLERANCES UNLESS OTHERWISE STATED

FABRICATION	MACHINING	ANGULAR
2 to 30 ± 1	0.5 up to 3 ± 0.05	up to 400 ± 45'
>30 up to 120 ± 2	>3 up to 6 ± 0.05	>400 up to 1000 ± 30'
>120 up to 400 ± 2	>6 up to 30 ± 0.1	>1000 ± 20'
>400 up to 1000 ± 3	>30 up to 120 ± 0.15	
>1000 up to 2000 ± 4	>120 up to 400 ± 0.2	
>2000 up to 4000 ± 6	>400 up to 1000 ± 0.3	
>4000 up to 8000 ± 8	>1000 up to 2000 ± 0.5	
>8000 up to 120000 ± 10	>2000 up to 4000 ± 0.5	
>12000 up to 16000 ± 12		
>16000 up to 20000 ± 14		
>20000 ± 16		



T: +44 (0)1543 571 280  
F: +44 (0)1543 571 173  
E: sales@addfield.com  
www.addfield.com

Addfield Environmental Systems LTD  
Unit 9, Zone 4  
Burntwood Business Park  
Staffordshire  
WS7 3XD

PROJECT:  
**A50L**

TITLE:  
**Sale GA**

DRAWING No. A50L Sale GA  
SHEET 1 OF 1 SCALE: 1:60  
REV - A3

DATE	DRAWN	CHECKED	APPROVED	DATE	DRAWN	CHECKED	APPROVED	DATE	DRAWN	CHECKED	APPROVED	DATE	DRAWN	CHECKED	APPROVED	DATE	DRAWN	CHECKED	APPROVED				
D				C				B				A				19/07/2022	A.SKIDMORE						
COMMENTS				COMMENTS				COMMENTS				COMMENTS				COMMENTS				ISSUE FOR MANUFACTURE			
ZONES: xx				ZONES: xx				ZONES: xx				ZONES: xx				ZONES: xx							

Addfield Environmental Systems LTD  
This drawing and any information or descriptive material set out on it are the confidential and copyright property of Addfield Environmental Systems, and MUST NOT BE DISCLOSED, COPIED, LOANED in whole or part or used for any purpose without the written permission of Addfield Environmental Systems.