

Agriculture



SB Maintain Biosecurity with clean efficient agricultural waste destruction. Agricultural incinerator for poultry, sheep, swine and butchery waste. Protect your sites biosecurity.



Maintain your biosecurity through securely destroying a complete range of Agricultural and Farm waste. Designed and built along the latest advances in animal incineration. Achieving a 40% reduction in fuel consumption compared to alternative solutions, through having a multi layered brick based refractory.

Top loading with impact resistant reinforced concrete blocks for hard wearing easy operation.

DEFRA approved and compliant with EU Animal By Products Regulations. 1653lbs loading capacity.

Machine Specification

| | |
|-----------------------------------|--------------------------|
| External L x W x H (in) | 135" x 114" x 84.4"/159" |
| Internal L x W x H (in) | 64" x 85.5" x 31.5" |
| Chamber Volume (ft³) | 38.8 |
| Weight (approx tonnes) | 4.3 |
| Max Load Capacity (lbs) | 1653 |
| Nominal Burn Rate UK* (lbs/hr) | <100 |
| Burn Rate [Export Only]* (lbs/hr) | 100 - 165 |
| Thermal Capacity (kW) | 260 |
| Power Supply 50/60 hz | 210/230v |
| Door Aperture (in) | 61.6" x 42.1" |
| Control Panel | AI or PLC |
| Fuel Types | Diesel, LPG, N-Gas |
| Insulation Board | 1" Super-wool |
| Insulation Fire Brick | Grade E23 |
| Fire Brick (Alumina) | 42.5% |

*We reserve the right to change the specification, dimensions and quality of materials from time to time, so long as the alteration is minor or an improvement to the said product.

Primary Chamber

- Pre-cast block impact zone protecting refractory lining during loading.
- Heavily insulated internal brick refractory, constructed along an interlocking systems to ensure maximum strength and resilience.
- Premium grade high alumina content refractory brickwork delivering optimal thermal retention.
- Top loading counter balanced insulated access lid.
- Temperature controlled waste ignition burner automatic on-off, complete with internal air fans.

Secondary Chamber

- Fully insulated internal refractory lining. Constructed from high grade low thermal mass insulation.
- Temperature controlled Secondary chamber burnout burner with automatic on-off control, complete with internal air fans.
- Integrated combustion burner air fans automatically controlling distribution to designated areas.
- Temperature sensor mounting point at the top of the chamber, ensuring the chamber reaches the required 1800°F minimum, with a 2 second retention time.

Recommended Waste Types

| | | |
|--|--------------------|---|
| | Poultry & Chickens | ✓ |
| | Sheep & Lambs | ✓ |
| | Pigs & Sows | ✓ |
| | Goats | ✓ |

Agriculture

SB

Maintain Biosecurity with clean efficient agricultural waste destruction.



Waste Loading and De-Ashing

The agricultural range of incinerators are designed for top loading directly into the primary chamber. Loading can be manual or mechanically through digger or hydraulic bin tipper. To be loaded no more than once per day prior to operation. The incineration process will reduce the waste to approximately 3% volume, ash. The ash should be removed before the following waste is loaded to ensure optimum burn rates. Optional de-ashing doors are available

The Addfield Difference

- Pre-Fabricated 0.32" & 0.4" robust mild steel casing, seam welded and suitably stiffened/ braced where necessary.
- Optimised loading chamber for maximum operational capacity.
- Lightweight resilient refractory fibre insulated lid, providing a tight seal, giving excellent thermal efficiency.
- Counterweighted loading chamber lid for ease of use.
- Primary chamber lining thickness 7" rated up-to 2642°F
- Premium paint finish - Steel structures are painted using a two pack high grade paint system.
- Multi-layered refractory lining using fire bricks and insulation bricks, improving thermal efficiency.



Additional Operation Equipment



Bin Tipper

The Bin Tipper unit empties waste within the bin using a unique electro-hydraulic mechanism that can lift and tip more than 330lbs. Hands free loading ensures operators safety, when dealing with hazardous waste.



Fuel Tank

Allowing you to operate the incinerator in all locations as well as providing a backup to your traditional supply. Available in 220 to 1100 gallon capacity. Fuel can be safely stored in close proximity to your incinerator.



Control Panel

Specially designed control panels, to manage your incineration. Pre-programmed and able to be manually adjusted for optimal results. Push button and touch screen control with optional data logging system.

SB

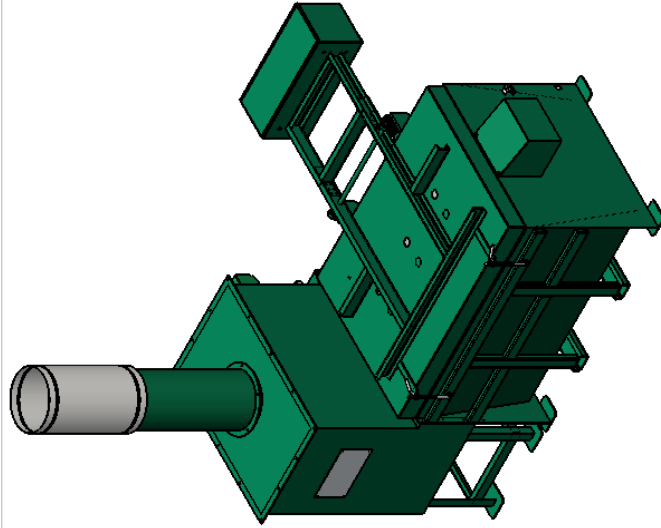

ISOMETRIC VIEW

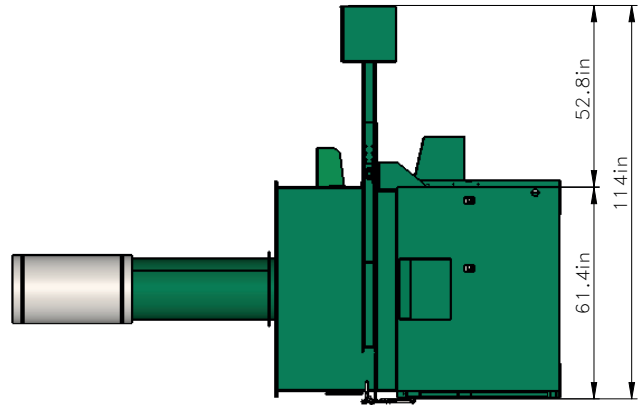

SIDE VIEW

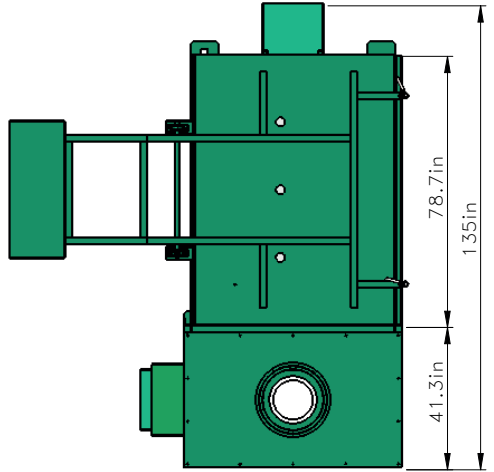

PLAN VIEW

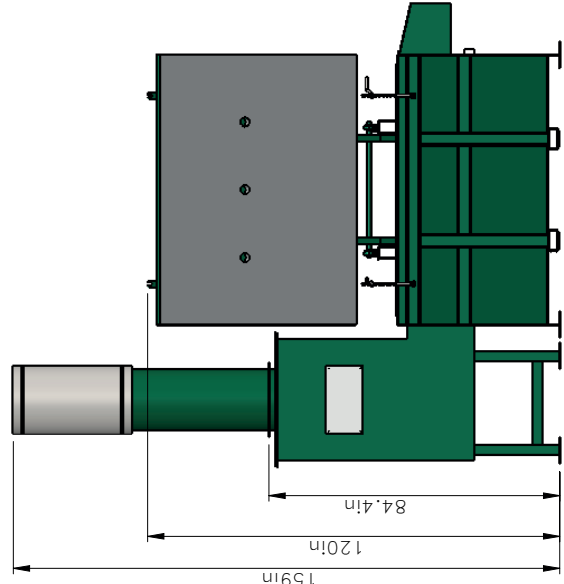

FRONT VIEW
OPEN LID

| DATE | DRAWN | CHECKED | APPROVED | DATE | DRAWN | CHECKED | APPROVED | DATE | DRAWN | CHECKED | APPROVED | DATE | DRAWN | CHECKED | APPROVED |
|------|-------|---------|----------|------------|-------|---------|----------|------|-------|---------|----------|------|-------|---------|----------|
| D | | | | | | | | | | | | | | | |
| C | | | | | | | | | | | | | | | |
| B | | | | | | | | | | | | | | | |
| A | | | | 28/03/2019 | KJ | HB | HB | | | | | | | | |

ADDFIELD ENVIRONMENTAL SYSTEMS LTD (2018)
 Addfield Environmental Systems Ltd and its logo are the confidential and
 copyright property of Addfield Environmental Systems, and
 MUST NOT BE DISCLOSED, COPIED, LOANED in whole or part
 without the written permission of
 Addfield Environmental Systems.

COMMENTS
 FIRST ISSUE

Measurements in Inches (in)
 THIRD ANGLE PROJECTION
 (UNLESS STATED OTHERWISE)

MATERIAL: N/A
 FINISH: N/A
 TOLERANCES (UNLESS STATED OTHERWISE)
 WHOLE NUMBERS ±1.00
 1 DECIMAL PLACE ±0.10
 2 DECIMAL PLACE ±0.05
 ANGLES ±0.50°

WEIGHT: 9479 LBS



Addfield Environmental Systems LTD
 Unit 9, Zone 4
 Burntwood Business Park
 Staffordshire
 WS7 3XD
 T: +44 (0)1543 571 280
 F: +44 (0)1543 571 173
 E: sales@addfield.com
 www.addfield.com

DRAWN BY: KJ
 DATE CREATED: 28/03/2019
 PROJECT:

STANDARD – SB

TITLE:

SB-GA

| | |
|------------------------|-------------|
| DRAWING No. 4-001-2 | REV - |
| SHEET No. 1 OF 1 | SCALE: 1:40 |
| A3 | |