

Agriculture

A50L For complete and secure destruction of agricultural waste.

The A50L agriculture incinerator is ideal for general animal waste produced by farms including poultry, sheep, pigs, goats and cattle.



The A50L is a high capacity animal incinerator, designed to handle waste such as pigs, cattle, sheep, butchers waste and poultry. Having a front-loading design, enabling a safe and easy method for continuous loading of animals.

Biosecurity is a growing concern for farmers across the globe, the implementation of an Addfield A50L can improve your ability to maintain a clean and safe environment for your livestock.

The following information details the many features, specifications and optional equipment associated with our A50L incinerator.

Machine Specification	
External L x W x H (mm)	3735 x 3175 x 3600/7200
Internal L x W x H (mm)	3035 x 1170 Ø
Chamber Volume (m ³)	3.26
Weight (approx tonnes)	8.6
Max Load Capacity (kg)	1200
Nominal Burn Rate	50 - 100
Thermal Capacity (kW)	770
Power Supply 50/60 hz	210/240v
Door Aperture	1170 Ø
Control Panel	AI or PLC
Fuel Types	Diesel, LPG, N-Gas
Fire Brick (Alumina)	42.5%
Insulation Fire Brick	Grade E23

*We reserve the right to change the specification, dimensions and quality of materials from time to time, so long as the alteration is minor or an improvement to the said product.

Primary Chamber

- Heavily insulated internal refractory lining. Constructed from high grade refractory brick ensuring a secure self-supporting, interlocking arrangement.
- Manually opening, securely locking, access door with viewing port.
- Automatic temperature controlled on-off waste ignition burner complete with internal air fans.
- Temperature controlled, on-off combustion burners, complete with internal air fans.
- One temperature sensor mounting points.

Secondary Chamber

- Fully insulated internal refractory lining. Constructed from high grade refractory brick and low thermal mass insulation.
- Secondary chamber burnout burner, temperature controlled on-off complete with internal air fans
- Automatically controlled integrated combustion burner air fans.
- Temperature sensor mounting point at the base of the exit flue ensuring the chamber reaches the necessary 850°C minimum, with a 2 second retention time.
- Secondary combustion burner air fans, automatically controlled distribution to their designated area.

Recommended Waste Types

	Poultry & Chickens	✓
	Sheep & Lambs	✓
	Pigs & Sows	✓
	Goats	✓
	Cows & Cattle	✓

A50L For complete and secure destruction of agricultural waste.



Waste Loading and De-Ashing

The A50L incinerator is designed for front loading only through the main access door. Due to the type of wastes they incinerate, bio-security measures should be in place on the site of the incinerator due to the possibility of spillage and spread of disease. At the end of every incineration process ash should be discharged through the loading door into a catcher tray prior to being loaded for the next burn.

The Addfield Difference

- Pre-Fabricated 8mm & 10mm robust mild steel casing, seam welded and suitably stiffened/ braced where necessary.
- Lightweight resilient refractory fibre insulation door, providing a tight seal, giving excellent thermal efficiency.
- Primary chamber lining thickness 150mm rated up-to 1450°C. Manufactured using our unique 3 layered brick based refractory, with a reinforced concrete finish around the door and along the floor.
- Premium paint finish - Steel structures are painted using a two-pack high grade paint system.
- Multi-layered refractory lining using fire bricks and insulation bricks, improving thermal efficiency.
- Multi-lingual control panel options.



Additional Operation Equipment



Ram Loader

Built to enable the option of continuous loading throughout operation. Securely positioning waste into the primary chamber whilst maintaining temperature and preventing radiant heat and thermal shock.



Chute Loader

A top loading chute system aids the continuous loading of waste during operation. Ideal for use with a bucket loading tipper system.

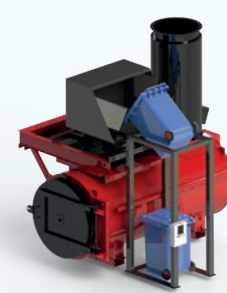

Bin Tipper

An Automatically bin tipper system provides hands free loading of hazardous waste.

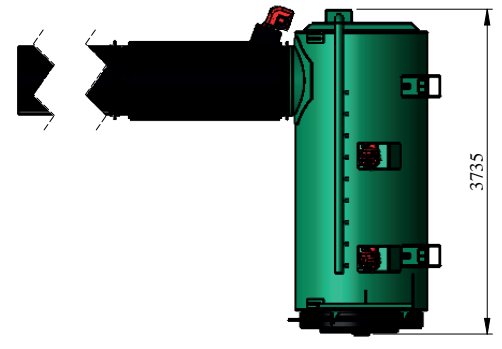
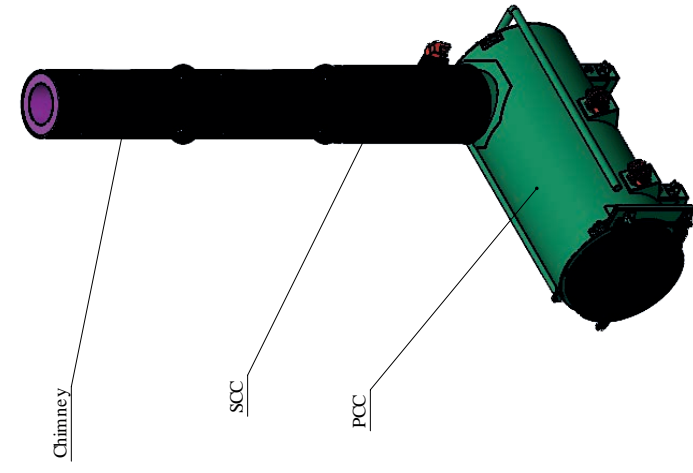
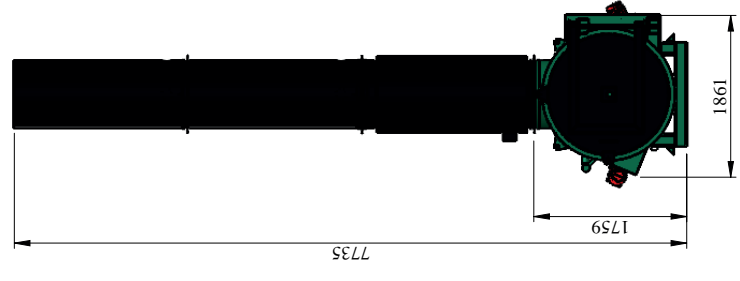
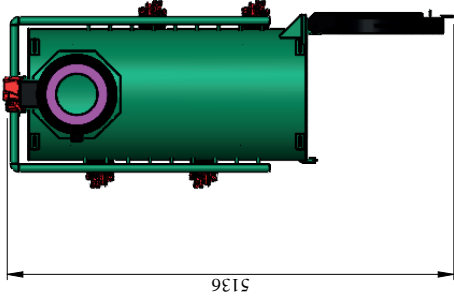

DATE	DRAWN	CHECKED	APPROVED	DATE	DRAWN	CHECKED	APPROVED	DATE	DRAWN	CHECKED	APPROVED
				18/07/2022	ASK/MS/RE						
COMMENTS: ISSUE FOR MANUFACTURE											

Add: add Environmental Systems LTD
 This drawing and any information or description contained on or in it are the sole domain and copyright property of Add Environmental Systems LTD and must not be disclosed, copied, loaned or otherwise used for any purpose without the written permission of Add: add Environmental Systems.

DRAWING No.		REV
A50L-Sale GA		-
SHEET 1 OF 1	SCALE:	A3
	1:50	

TITLE
 A50L
 Sale GA

PROJECT:
 Add: add Environmental Systems LTD
 Unit 9, Zone 4
 Burntwood Business Park
 Sta. ordshire
 www.add: add.com
 WS7 3XD

MATERIAL: N/A
FINISH: N/A
WEIGHT: N/A

THIRD ANGLE PROJECTION
 (UNLESS STATED OTHERWISE)

TOLERANCES UNLESS OTHERWISE STATED

FABRICATION	MACHINING	ANGULAR
± 1	0.5 up to 0.3	± 0.05
± 2	> 0.5 up to 0.2	± 0.05
± 2	> 0.2 up to 0.05	± 0.1
± 0.1	0.05 up to 0.02	± 0.05
± 0.1	> 0.05 up to 0.02	± 0.05
± 0.2	> 0.02 up to 0.005	± 0.2
± 0.2	> 0.005 up to 0.002	± 0.2
± 0.5	> 0.002 up to 0.001	± 0.5
± 1	> 0.001 up to 0.0005	± 1
± 1.4	> 0.0005 up to 0.0002	± 1.4
± 1.6	> 0.0002	± 1.6

addfield
 Incinerate • Cremate

MATERIAL: N/A
FINISH: N/A
WEIGHT: N/A

THIRD ANGLE PROJECTION
 (UNLESS STATED OTHERWISE)

TOLERANCES UNLESS OTHERWISE STATED

FABRICATION	MACHINING	ANGULAR
± 1	0.5 up to 0.3	± 0.05
± 2	> 0.5 up to 0.2	± 0.05
± 2	> 0.2 up to 0.05	± 0.1
± 0.1	0.05 up to 0.02	± 0.05
± 0.1	> 0.05 up to 0.02	± 0.05
± 0.2	> 0.02 up to 0.005	± 0.2
± 0.2	> 0.005 up to 0.002	± 0.2
± 0.5	> 0.002 up to 0.001	± 0.5
± 1	> 0.001 up to 0.0005	± 1
± 1.4	> 0.0005 up to 0.0002	± 1.4
± 1.6	> 0.0002	± 1.6