

High Capacity

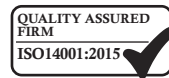

MOBILE RAPID1000

The large scale, RAPID1000 incinerator is the latest innovative design from Addfield joining our High Capacity incineration range.

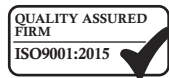

The Rapid1000 high capacity incinerator is an ideal solution to batch loading of solid waste. Having a 3000kg loading capacity and reinforced loading chamber enables even large carcasses to be easily loaded. Designed for easy and fast deployment for on a road legal flat rack for static operation. Providing essential support to maintaining biosecurity.

Built to rapidly handle a wide range of solid waste able to achieve a burn rate of up to 1000kg/hr. A highly robust and thermally efficient solution benefiting from an advanced burn chamber to ensure a smooth and equal burn. Multiple sub chamber doors allow rapid de-ashing during and after the incineration process has been completed.

Machine Specification

External L x W x H (mm)	8206 x 2325 x 2273/6470
Internal Upper Chamber L x W x H (mm)	3710 x 1510 x 1125(peak)
Internal Lower Chamber L x W x H (mm)	3710 x 1510 x 370
Load Chamber Volume (m ³)	5.1
Weight (approx tonnes)	26.2
Max Load Capacity (kg)	5000
Nominal Burn Rate (kg/hr)	500 to 1000
Thermal Capacity (kW)	2250
Power Supply 50/60 hz	318/415v
Door Aperture	3650 x 1450
Control Panel	PLC
Fuel Types	Diesel, LPG, N-Gas
Insulation Board	25mm Super-wool
Insulation Fire Brick	Grade E23
Fire Brick (Alumina)	42.5%

*We reserve the right to change the specification, dimensions and quality of materials from time to time, so long as the alteration is minor or an improvement to the said product.

Primary Chamber

- Fully insulated internal refractory lining, constructed from high grade refractory brick ensuring a self-supporting, interlocked arrangement.
- Fully interlocked, pneumatically operated, access door.
- Waste ignition burner, temperature controlled on-off, complete with internal air fans.
- Grated hearth combustion burner, temperature controlled on-off, complete with internal air fans.
- Below grate combustion burner air fans with automatically controlled distribution to their designated area.

Secondary Chamber

- Fully insulated internal refractory lining. Constructed from high grade low thermal mass insulation.
- Temperature controlled Secondary chamber burnout burner with automatic on-off control, complete with internal air fans.
- Integrated combustion burner air fans automatically controlling distribution to designated areas.
- Temperature sensor mounting point at the top of the chamber, ensuring the chamber reaches the required 850°C minimum, with a 2 second retention time.

Waste Type

Agricultural Waste	✓
Medical Waste	✓
General (municipal) Waste	✓

High Capacity



Waste Loading and De-Ashing
 Loading can be carried out either mechanically or manually through the vertical opening hydraulically operated lid. Ash is removed manually through the front ash doors, a full set of de-ashing tools are included with every Rapid machine. To de-ash simply push the de-ashing button on the control panel, this will isolate the lower burners to allow ash doors to open for ash removal.

The Addfield Difference

- Pre-fabricated 8mm & 10mm robust mild steel casing, seam welded and suitably stiffened/ braced where necessary.
- Lightweight resilient refractory fibre insulation lid, providing a tight seal, giving excellent thermal efficiency.
- Primary lining thickness 190mm, rated at 1450°C.
- Low thermal mass roof lining
- Paint finishing – The steel structures are completely painted using a two-pack high grade paint system.
- Unique Grated Hearth technology designed for the increased efficiency of material incineration.
- A 190mm thick refractory lining, using andalusite and insulation bricks, improving thermal efficiency.



Additional Operation Equipment



Control Panel

Specially designed control panels, to manage your incineration. Pre-programmed and able to be manually adjusted for optimal results. Push button and touch screen control with optional data logging system.



Fuel Tank

Allowing you to operate the incinerator in all locations as well as providing a backup to your traditional supply. Available in 1000 to 5000 litre capacity. Fuel can be safely stored and monitored in close proximity to your incinerator.



Venturi System

An advanced flue gas treatment system designed to further reduce dust, acid gasses, dioxins and furans. Highly effective the venturi is widely regarded as the leading treatment system in its field.

Mobile Position

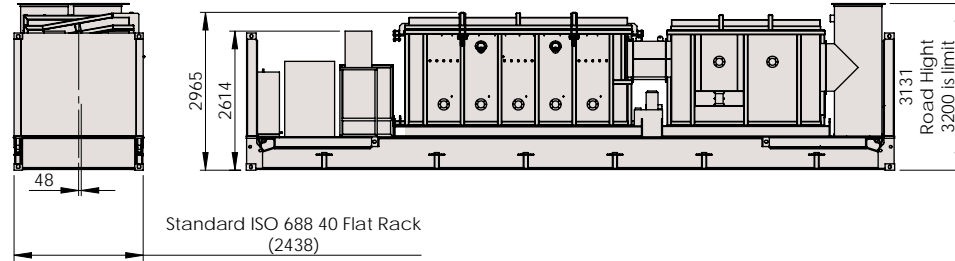
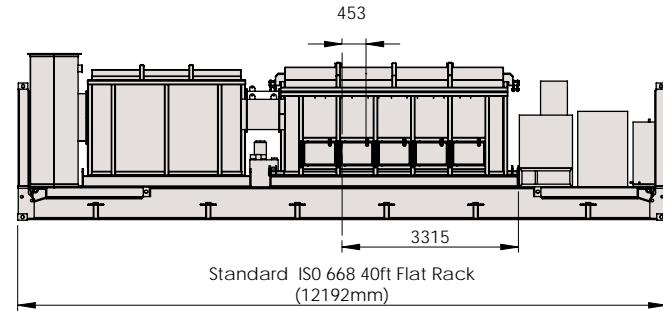
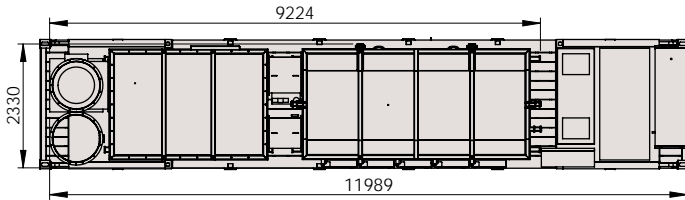

Fan	300kg (661lb)
burners	250kg (551lb)
electrical parts	75 (165lb)
buffer	1000 (2204lb)

Flat Rack is an ISO standard 668 40ft Flat Rack (for measurement this is just a guide derived from the iso standard)
 These are dry weights when system is empty
 Top Two Burners and SCC Fan needs to be removed for tranport

Operational Position

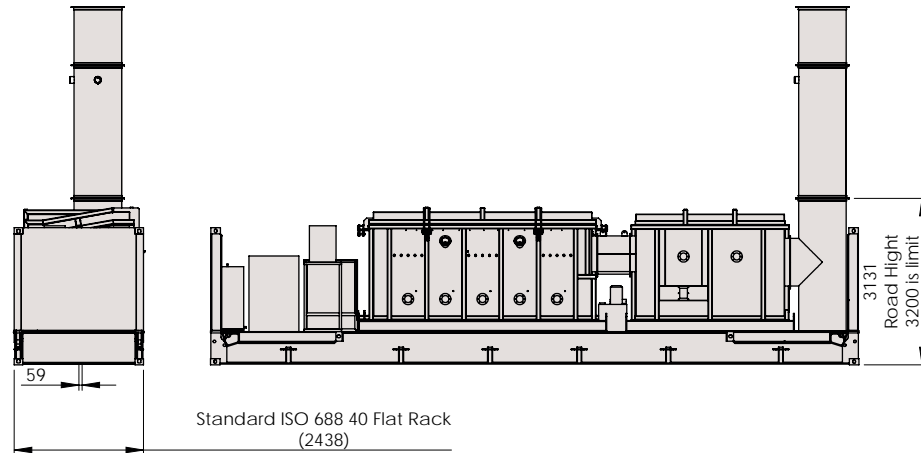
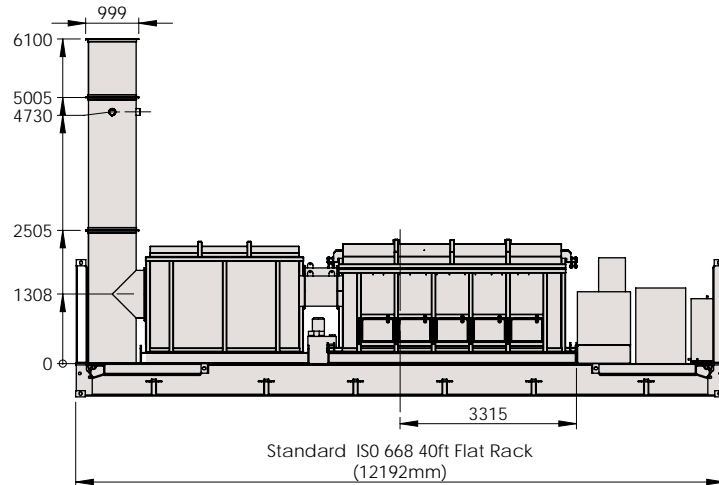
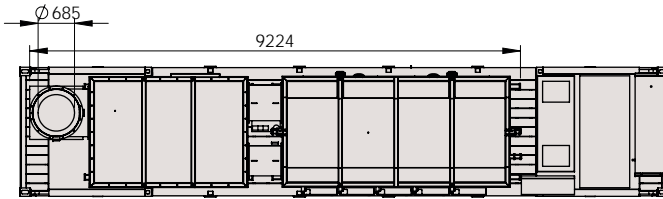

MATERIAL:	N/A	FINISH:	N/A
-----------	-----	---------	-----

WEIGHT: 23,500Kg (51808lb) +5,000kg (11,023lb)

THIRD ANGLE PROJECTION (UNLESS STATED OTHERWISE)

TOLERANCES UNLESS OTHERWISE STATED		
FABRICATION	MACHINING	ANGULAR
2 to 30	± 1	0.5 up to 3 ± 0.05
>30 up to 120	± 2	up to 400 ± 45'
>120 up to 400	± 2	>3 up to 6 ± 0.05
>400 up to 1000	± 3	>6 up to 30 ± 0.1
>1000 up to 2000	± 4	>30 up to 120 ± 0.15
>2000 up to 4000	± 6	>120 up to 400 ± 0.2
>4000 up to 8000	± 8	>400 up to 1000 ± 0.3
>8000 up to 12000	± 10	>1000 up to 2000 ± 0.5
>12000 up to 18000	± 12	>2000 up to 4000 ± 0.5
>18000 up to 20000	± 14	
>20000	± 16	



T: +44 (0)1543 571 280
 E: sales@addfield.com
 www.addfield.com

Addfield Environmental Systems LTD
 Unit 9, Zone 4
 Burntwood Business Park
 Staffordshire
 WS7 3XD

PROJECT:
Rapid 1000 Mobile

TITLE:
GA

DATE	DRAWN	CHECKED	APPROVED	DATE	DRAWN	CHECKED	APPROVED	DATE	DRAWN	CHECKED	APPROVED	DATE	DRAWN	CHECKED	APPROVED	DATE	DRAWN	CHECKED	APPROVED	

Addfield Environmental Systems LTD
 This drawing and any information or descriptive material set out on it are the confidential and copyright property of Addfield Environmental Systems, and MUST NOT BE DISCLOSED, COPIED, LOANED in whole or part or used for any purpose without the written permission of Addfield Environmental Systems.

DRAWING No.	88-01-08	REV	-
SHEET 1 OF 1	SCALE: 1:100		A3